



21027

FRAISE Z1
POUR ALUMINIUM

FRÄSER Z1
FÜR ALUMINIUM

ENDMILL Z1
FOR ALUMINIUM



Compatibilité outil/matière • Werkzeug - /Werkstoffverträglichkeit • Tool/material compatibility: ● 1/3 ● 2/3 ● 3/3

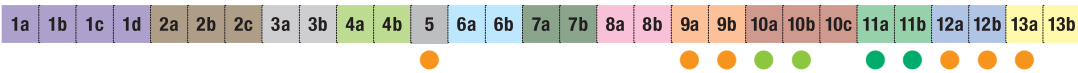

▶ E2

D	d	d3	L	l1	l3	z	REF
h10	h6						
6	6	5.50	57	13	25	1	6
8	8	7.40	63	19	36	1	8
10	10	9.20	72	22	45	1	10
12	12	11	83	26	53	1	12

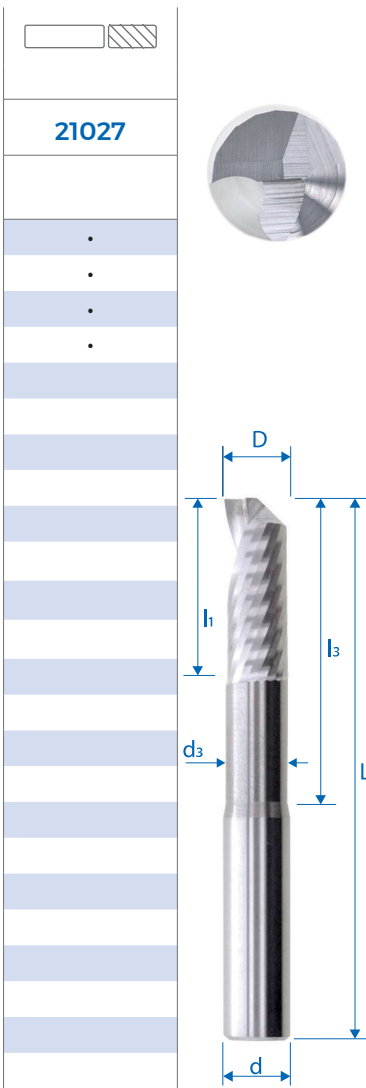

FINITION • SCHLICHTEN • FINISHING

FRAISAGE • FRÄSER • ENDMILL